

Manhole(M/H)부 상세(1/5)

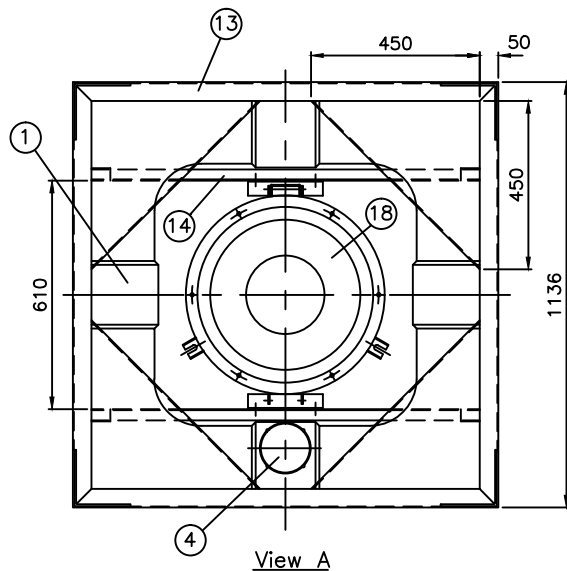

View A

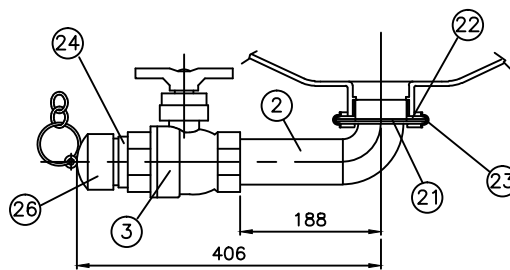

배출관부 상세(1/7.5)

26	Dust cap	1	50A	N R	
25	Cushion rubber		—	N R	
24	Camlock		50A	PPG	
23	Clamp		1.2t	SUS304	
22	Lap joint		65A	SUS304	
21	Packing	1	$\phi 120 \times 4t$	EPDM	
20	Handle nut	2	M10	SUS304	Zn 도금
19	경첩볼트	2	M10x65	SUS304	
18	M/H cap	1	$\phi 530$	PP/SS41	Zn 도금
17	M/H inner cap	1	$\phi 420$	P E	
16	M/H band	1	L20x20x3t	SS41	Zn 도금
15	Valve holder	1	32x2.3t	G I	
14	Tank holder	2	L50x30x2.3t		
13	상판 Frame	1	L50x50x2.3t		
12	Hopper 기둥	4	L50x50x2.3t		
11	Hopper	1	1.2t	G I	
10	Pallet	1	—	SS41	Zn 도금
9	Step	1	$\phi 12$	SS41	Zn 도금
8	Center보강	4	2.3t	G I	
7	Card holder	1	2.3t		
6	측 판	4	1.2t		
5	수직기둥	4	L60x26x2.3t	G I	
4	Air cap	1	100A	P E	
3	Ball valve		50A	PVC	
2	배출관		50A	SUS304	
1	Tank	1	1050 L	P E	

No.	DESIGNATION	QT'Y	SIZE	MATERIAL	REMARKS
DATE: 97.12.17					SCALE 1/15
DESIGN	TITLE P4-H 1200L Container				SHEET
CHECK	DWG No. P4H-A1/p-a				SHEETS
APP'D					



(주)에이치피티
HANKUK POLY TANK Co.,LTD