

Manhole(M/H) ??? (1/5)

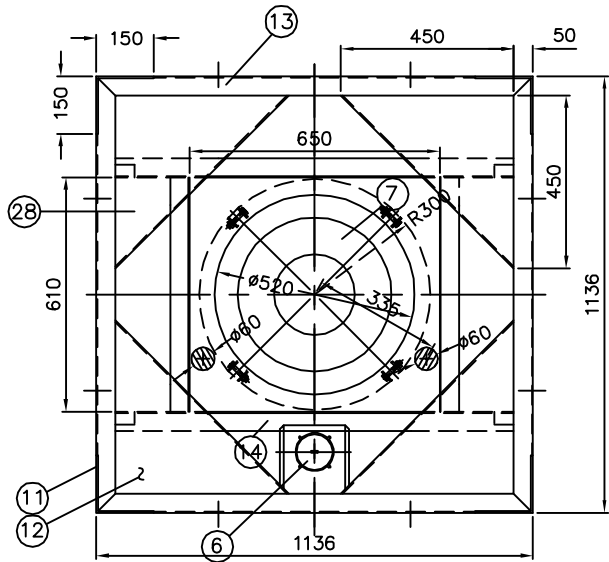

View C

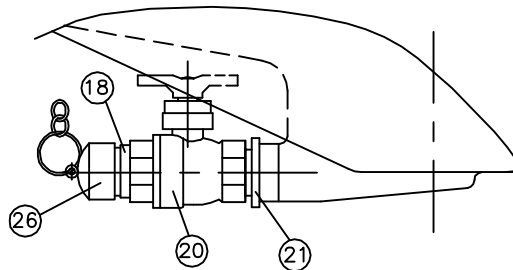

???(1/7.5)

28	Tank	1	1050L	P E	
26	Dust cap	1	65A	알미늄	
25	M/H inner cap	1	ø420	P E	
24	M/H band	1	L20X20X3t	SS41	
23	Handle nut	2	M10	SUS304	
22	경첩볼트	2	M10X65	SUS304	
21	Valve nipple		50A → 60A	P P	
20	Ball valve		65A	STS	Packing:teflon
19	Pallet base	7	FB50x9t		Zn 함침도금
18	Camlock	1	65A	STS	
17	Pallet 기둥 B	5	100x40x20x2.3t		
16	Pallet 기둥 A	4	100x50x2.3t		
15	수직기둥보강	4	100x60x30x2.3t	GI	
14	Tank holder	2	50x50x4t	GI	
13	상판 Frame	4	50x50x2.3t		
12	상판삼각보강	4	450x30x2.3t	GI	
11	Stopper	4	FB150x150x4.5t	SS41	Zn 도금
10	Step ladder	1	200x100x30(ø12)	SS41	Zn 도금
9	Hopper 기둥	4	50x50x2.3t	GI	
8	Card holder	1	2.3t		
7	M/H CAP	1	ø530	PP/SS41	아연용융도금
6	Air cap	1	80A	PE	
5	측판	4	1060x914x1.2t		
4	측면중간보강		100x25x20x2.3t		
3	측면하부보강		60x60x2.3t		
2	상부보강		50x24x20x2.3t		
1	수직기둥	4	60x26x2.3t	GI	
No.	DESIGNATION	QT'Y	SIZE	MATERIAL	REMARKS

DATE:10.01.20				SCALE	1/15
DESIGN		TITLE		SHEET	
CHECK		P4-KC frame ass'y(운반08-07)			
APP'D		DWG NO.		SHEETS	
		P4C-B1/p4cf			